

SAFES

VAULTS AND VAULT DOORS



Chubbsafes
Trusted the world over.

MAKE SECURITY A PART OF YOUR EVERYDAY LIFE

Trusted the world over, Chubb safes is the oldest brand for safes, vaults and vault doors in the world. Chubb safes solutions are well known and appreciated for their unique combination of robustness, reliability and modern designs. Having provided high-quality protection solutions for almost two centuries, Chubb safes combines experience with innovation to create trustworthy products for maximum protection against burglary, fire and explosives. The Chubb safes solutions are rigorously tested by international and independent accreditation bodies to guarantee the best protection available.



Chubb safes
Trusted the world over.

CONTENTS

| | |
|-----------------------------------|----|
| FINDING YOUR SAFE | 5 |
| TEST STANDARDS & PRODUCT OVERVIEW | 6 |
| LOCKING OPTIONS | 8 |
| PRODUCTS | |
| OPTIONAL FITTINGS | 34 |

| | |
|-------------------|----|
| Air | 9 |
| Air Hotel | 10 |
| Viper | 11 |
| Senator | 12 |
| Cube Safe | 13 |
| E-slot Safe | 14 |
| Omni | 15 |
| Omni Drawer Trap | 16 |
| DuoGuard | 17 |
| Oxley MK III | 18 |
| Eurpoa GIII | 19 |
| Europa GV | 20 |
| Archive Cabinet | 21 |
| DPC | 22 |
| Fire File 25" | 23 |
| Fire File 31" | 24 |
| DataGuard NT | 25 |
| DataPlus+ | 26 |
| Counter Unit | 27 |
| Pistol Safe | 28 |
| Deposit Container | 29 |
| Drug Safe | 30 |
| InstaVault | 31 |
| Vault Doors | 32 |

ICONS EXPLAINED



Burglary



Fire
paper doc.



Fire
data media



SIMPLY FIND YOUR PRODUCT

The Chubb safes Product Selector is designed to assist you in finding the right product. It is easy to navigate and helps you determine what you are looking for by product feature, valuable to protect, locking solution or protection needed. Not sure which safe to choose to protect your documents, your electronics or jewellery? The Chubb safes Product Selector helps you compare products in order to make the right purchasing decision.

CHECK IT OUT AND FIND YOUR NEAREST LOCAL
CHUBBSAFES CONTACT ON WWW.CHUBBSAFES.COM.AU

WHICH SAFE IS RIGHT FOR YOU?

The most important initial question is what you want to protect – cash and valuables, documents or data media?

CASH AND VALUABLES

Choose from the burglary protection range. This includes safes, cabinets, vaults & vault doors, designed to withstand physical attacks in different strengths or Grades. Each Grade represents a particular “cash rating” which is the amount an insurer will cover*.

* The actual amount of cover can vary between insurance companies and country, and may be different to the manufacturer’s recommended rating. You should always check what cover your insurance company is prepared to offer.

DOCUMENTS AND DATA MEDIA

Choose from the fire protection range which includes safes and filing cabinets designed to keep documents or data media safe from the effects of a fire.

DOCUMENTS

To survive a fire, documents require protection from temperatures higher than 177°C. Therefore cabinets have to be specifically designed, tested and then certified for this task. Without a credible certification, you cannot be sure that your documents are safe.

DATA MEDIA

The same is valid for data media, except here the cabinet must offer much greater protection due to the sensitivity of the material. If the inside of the cabinet exceeds a mere 55°C, then the information on a CD, DVD or tape will be destroyed.



CERTIFIED STRENGTH

To provide the appropriate level of protection, the products are tested to comply with the latest industry standards. The various certification tests carried out in independent laboratories for burglary or fire protection are conducted by experienced operators armed with plans of the product and a whole range of tools.

FOR BURGLARY PROTECTION, safes and vaults are awarded grades:

- For security cabinets, there are Grades S1 and S2 (EN 11450).
- For safes, vaults and vault doors, they are rated from Grade 0 to Grade XIII (EN 1143-1) and from class TL-15 to class 3 (UL 687 and UL 608).
- High security locks are graded according to EN 1300 or UL 1034 and security doors sets, windows and partitions are ranked from RC1 to RC6 (EN 1127).

During the certification process, door panels of the products, bolt works, locks and handles are tested. The certification tests include an attack program that is devised so that various break-in attempts can be made using a selection of tools. A correlation between tool type and the time for which each one is used can be used to obtain a resistance score (resistance unit). The higher the score, the higher the level of resistance. Based on the results obtained, the safe is given a classification and then listed in a resistance grade.

FOR FIRE PROTECTION, these standards vary according to whether you want to protect paper documents, digital media or other highly sensitive objects. This is because the temperature at which data media (e.g. 52°C) and documents (e.g. 177°C) deteriorate differs according to the item protected:

- In order to fully protect data media, industry standards indicate that products should carry ECB•S EN 1047-1, UL 72 Class 125 or NT Fire 017 60/120 DIS.

The ECB•S and UL tests monitor the internal temperature of the data cabinet until it has completely cooled down during the “soakout” period. Assessing products during this period is essential, since internal temperatures can peak up to six to eight hours after a fire has been extinguished. Such tests ensure that all products are comprehensively tested and, upon passing, will fully protect your data media for the specific time period stated.

- For document protection, all products must have an appropriate industry standard 30- or 60-minute paper certificate.

UL72-Class 350, ECB•S EN 1047-1, EN 15659 or NT Fire 017 are acceptable standards for paper document protection.

LEVELS OF RESISTANCE

Alongside extremely strict standards, you will also find a number of others that are less stringent in terms of resistance.

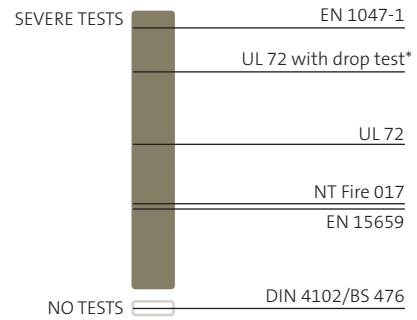

* Test UL 72 does not necessarily involve conducting a drop test.

HIGHEST ALLOWED INSIDE TEMPERATURE

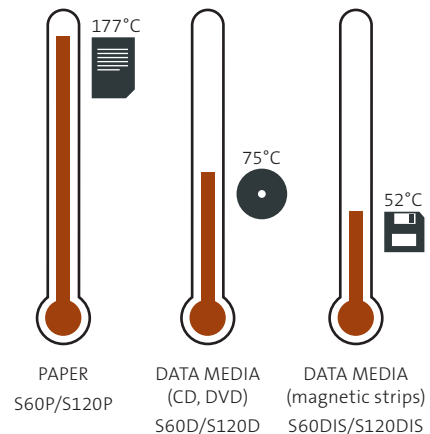

STANDARDS IN BRIEF

| STANDARDS | TEMPERATURE TEST | DROP TEST | PAPER | DATA MEDIA | COOLING |
|-----------------|------------------|--------------|---|--|--------------------------|
| EN 1047-1 | 1090°C | 9.15 metres | S 60P (60 min.) / S 120P (120 min.) | S 60DIS (60 min.) / S 120DIS (120 min.) | incl. the cooling period |
| UL 72 | 1000°C | 9.15 metres* | Class 350 (1/2, 1, 2 hours) | Class 125 (1/2, 1, 2 hours) | incl. the cooling period |
| EN 15659 | 850°C | no | LFS 30P (30 min.) / LFS 60P (60 min.) | no application | not tested |
| NT Fire 017 | 927°C | no | 60 paper (60 min.) / 120 paper (120 min.) | 60 diskettes (60 min.) / 120 diskette (120 min.) | not tested |
| DIN 4102/BS 476 | not tested | not tested | not tested | not tested | not tested |

* Test UL 72 does not necessarily involve conducting a drop test.

EUROPEAN CERTIFICATION FOR SAFES, VAULTS AND VAULT DOORS EXPLAINED

In order to attest to the quality of a certified product, an information plate is adhered to the inside of the product. This provides you with guarantees that the product has been tested and manufactured in an environment that has been checked by the certifying body.

Below is shown the ECB-S label and the details listed on the information plate.

BURGLARY PROTECTION CERTIFICATION

| | | | |
|--|---|--|---|
| <p>SERIAL NO. Each product can be identified by a unique serial number. This number is given by the certifying body</p> | <p>EN 1143-1/EN 14450 The European standard that the product meets</p> | <p>CERT. MARK. NO. Certificate number issued by the certifying body</p> | <p>RESISTANCE GRADE Resistance classes</p> |
| <p>YEAR OF MANUFACTURE The year that the product was manufactured</p> | | | <p>WEIGHT The safe's net weight. A 15% tolerance in the net weight indicated is accepted</p> |

Through partnerships entered into with the ECB-S, the bodies listed here issue identical certificates: VdS (Germany), ICIM (Italy), a2p (France), SBSC (Sweden).

FIRE PROTECTION CERTIFICATION

| | | | |
|--|---|--|---|
| <p>SERIAL NO. Each product can be identified by a unique serial number. This number is given by the certifying body</p> | <p>EN 1047-1/EN 15659 The European standard that the product meets</p> | <p>CERT. MARK. NO. Certificate number issued by the certifying body</p> | <p>PROTECTION CLASS Resistance classes</p> |
| <p>YEAR OF MANUFACTURE The year that the product was manufactured</p> | | | <p>WEIGHT The safe's net weight. A 15% tolerance in the net weight indicated is accepted</p> |

Fire certification is issued by independent approved laboratories. Here are some examples of test institutes and certificates that you may encounter: ECB-S, UL, iBMB, MPA Dresden, Applus RTD, SP, VdS.

FOR MORE DETAILED INFORMATION, contact your insurance company or visit the chubbsafes.com website.

LOCKING OPTIONS

Depending on the range, you can customise your product with a different lock. Thus you can benefit from a comprehensive lock offering that includes the latest industry solutions, which offer a wide range of features. So whether it be the “mechanical combination” lock or an electronic solution, you can be sure to have a lock that will meet your security needs. Below the key terms associated with the range of locks.

Definitions:

KEY LOCK: A manual key-operated lock.

MECHANICAL COMBINATION: A mechanical keyless dial lock with a changeable combination.

ELECTRONIC LOCK: An electronically-operated keypad lock with a changeable combination.

MANAGER MODE: Allows one user to control the functions of other combination holders.

NUMBER OF USERS: The number of users able to program in their own access code.

DURESS FEATURE: An alarm engineer can link the lock into a monitored alarm system. Then, using a given procedure, the lock can be operated, the safe opened and a silent signal given to the monitoring station that this is being done under duress.

TIME DELAY: This feature allows for a pre-set delay between operating the lock and being able to open the safe. The operation may vary between lock types.

TIME LOCK: Time lock allows the user to set periods during which the lock may be operated, e.g. during business hours only. The options available will vary between locks.

AUDIT TRAIL: The lock is able to give a report (it will vary in detail from model to model) of usage and may show times of operation, codes used and operations performed.

DUAL CONTROL: Allows two users to enter their details before any operation can be performed.

SAFES, VAULTS AND VAULT DOORS BY CERTIFICATION

| PRODUCT | CERTIFICATION STANDARD | PROTECTION OR RESISTANCE LEVEL | CERTIFICATION BODY |
|--|--|--------------------------------|--------------------|
| BURGLARY PROTECTION | | | |
| Air | n/a | n/a | n/a |
| Cube Safe | n/a | n/a | n/a |
| E-slot Safe | n/a | n/a | n/a |
| Counter Unit | n/a | n/a | n/a |
| Drug Safe | n/a | n/a | n/a |
| Omni Drawer Trap | n/a | n/a | n/a |
| Europa GIII | EN 1143-1 & AS/NZS 3809 | Grade III & Level 3 | ECB•S & AS/NZS |
| Europa GV | EN 1143-1 & AS/NZS 3809 | Grade V & Level 5 | ECB•S & AS/NZS |
| Pistol Safe | n/a | n/a | n/a |
| Deposit Container | n/a | n/a | n/a |
| InstaVault | n/a | n/a | n/a |
| Vault Doors | n/a | n/a | n/a |
| FIRE PROTECTION | | | |
| Archive Cabinet | n/a | n/a | n/a |
| Fire File 25" | UL 72 Class 350 | 1h Fire | UL |
| Fire File 31" | UL 72 Class 350 | 1h to 2h Fire | UL |
| DataGuard NT | NT Fire 017 | 120 min Diskette | SP |
| COMBINED BURGLARY AND FIRE PROTECTION | | | |
| Viper | EN 14450 & EN 15659 | Level S2 & 30 min Paper | ECB•S |
| Senator | EN 1143-1 & EN15659 | Grade 1 & 30min Paper | |
| DPC | UL 72 Class 350 | 2h | UL |
| Omni | JIS S 1037:1989 | 45min | JIS |
| DuoGuard | EN 1143-1 & EN 1147-1 | Grade 0 to I & S 60 P | ECB•S |
| Oxley MK III | EN 1047-1 | S 60 P | ECB•S |
| DataPlus+ | EN 14450 & EN 1047-1 & UL 72 Class 125 | Level S2 & 120 min Diskette | ECB•S & UL |



MODEL SHOWN: AIR 10 EL



AIR

BURGLARY-RESISTANT SAFE

KEY FEATURES

- Compact safe, ideal for home or office
- 4mm-thick steel door, 2mm-thick steel body frame
- Choice of key lock or electronic lock
- Three sizes available: 9-, 16- and 24-litres capacities. The largest is designed to accommodate most laptop computers

PRODUCT SPECIFICATIONS

| Model | EXTERNAL (mm) | | | INTERNAL (mm) | | | Volume (litres) | Weight (kg) | Standard internal fittings |
|---------------|---------------|-------|--------|---------------|-------|-------|-----------------|-------------|----------------------------|
| | Height | Width | Depth* | Height | Width | Depth | | | |
| Air 15 | 250 | 350 | 250 | 240 | 340 | 200 | 16 | 11 | 1 shelf |
| Air 25 Laptop | 200 | 430 | 350 | 190 | 420 | 300 | 24 | 13 | – |

Dimensions exclude handle and hinge projections. * In electronic models, add 20mm to allow for keypad projection.



MODEL SHOWN: AIR HOTEL



AIR HOTEL

BURGLARY-RESISTANT SAFE

KEY FEATURES

- Compact safe for burglary protection in hotel rooms, student residences or other high-turnover accommodations
- 4mm-thick steel door, 2mm-thick steel body frame
- Anchoring kit included to prevent from unauthorised removal
- Lock alternatives: Electronic lock with audit trail
- Designed to be used in hotel's only where multiple safes and continual new codes are required.

PRODUCT SPECIFICATIONS

| Model | EXTERNAL (mm) | | | INTERNAL (mm) | | | Volume (litres) | Weight (kg) |
|--------------|---------------|-------|-------|---------------|-------|-------|-----------------|-------------|
| | Height | Width | Depth | Height | Width | Depth | | |
| AIR Hotel EL | 200 | 430 | 350 | 190 | 420 | 300 | 24 | 13 |

CEU Unit - this unit is the override unit to be used with the Air Hotel

Dimensions exclude handle and hinge projections.



MODEL SHOWN: VIPER 50 EL

VIPER

BURGLARY- & FIRE-RESISTANT SAFE



KEY FEATURES

- Combined fire and burglary protection in one safe
- EN 14450 certified by ECB+S to level S2 burglary protection
- EN 15659 certified by ECB+S for 30-minute fire protection for documents
- Choice of 6 sizes: from 11- to 91-litre capacity
- Choice of locking options in all sizes: EN 1300 certified double-bitted key lock or EN 1300 certified electronic lock
- Dual base fixing holes, supplied with two concrete anchor bolts
- Ideal safe for protecting cash and valuable items, as well as passports, title deeds and other important documents in the home and office
- The safe door is secured using the new revolutionary “V” bolt system. The design of the locking bolts helps maintain door integrity both when under physical attack and during a fire

PRODUCT SPECIFICATIONS

| Model | EXTERNAL (mm) | | | INTERNAL (mm) | | | Volume (litres) | Weight (kg) | Standard internal fittings |
|-------|---------------|-------|--------|---------------|-------|-------|-----------------|-------------|----------------------------|
| | Height | Width | Depth* | Height | Width | Depth | | | |
| 10 | 300 | 360 | 300 | 210 | 270 | 191 | 11 | 21 | 1 shelf |
| 20 | 300 | 445 | 390 | 210 | 355 | 281 | 21 | 28 | 1 shelf |
| 35 | 450 | 445 | 390 | 360 | 355 | 281 | 36 | 38 | 1 shelf |
| 50 | 600 | 445 | 390 | 510 | 355 | 281 | 51 | 46 | 1 shelf |
| 70 | 800 | 445 | 390 | 710 | 355 | 281 | 71 | 59 | 2 shelves |
| 90 | 1000 | 445 | 390 | 910 | 355 | 281 | 91 | 72 | 2 shelves |

* Hinges project 20mm beyond the depth given above. In standard electronic models, the overall projection increases to 30mm.

* We recommend that Viper Model 70 and Model 90 are installed and delivered by a professional safe installer. Please refer to our Preferred Chubb Safes Installer list on page 33.



MODEL SHOWN: SENATOR M2

SENATOR

BURGLARY & FIRE-RESISTANT SAFE



EN 1143-1
Grade I



EN 15659
LFS 30P

KEY FEATURES

- Dual Certification: Burglary (EN 1143-1) Grade I and Fire (EN 15659, LFS 30P).
- Certified locks: EN 1300 certified Class A key lock or Class B high security electronic lock.
- Four sizes available: 32, 46, 63 or 190 litres.
- Secure bolt work and traditional heavy weight design.
- Enhanced design: removable door for easy installation and a reduced overall weight by 15%.
- Fittings: each safe is supplied with one shelf as standard.
- Attractive appearance: single-colour door and body in dark grey (RAL 7016).
- Ideal for the home or office.
- Cash Rating: \$45,000

PRODUCT SPECIFICATIONS

| Model | EXTERNAL | | | INTERNAL (mm) | | | Volume (litres) | Weight (kg) | Clear Opening Width | No. of bolts |
|-------|----------|-------|-------|---------------|-------|-------|-----------------|-------------|---------------------|--------------|
| | Height | Width | Depth | Height | Width | Depth | | | | |
| M1 | 370 | 500 | 403 | 290 | 420 | 263 | 32 | 119 | 404 | 5 |
| M2 | 500 | 500 | 403 | 420 | 420 | 263 | 46 | 146 | 404 | 5 |
| M3 | 650 | 500 | 403 | 570 | 420 | 263 | 63 | 178 | 404 | 4 |
| M4 | 862 | 654 | 563 | 782 | 574 | 423 | 190 | 326 | 558 | 4 |

*+55,27mm (handle protrudes from the surface)

* We recommend that these safes are delivered and installed by a professional safe installer. Please refer to our Preferred Chubb Safes Installer list on page 33.



CUBE SAFE

BURGLARY-RESISTANT SAFE



KEY FEATURES

- Burglary protection for around your home or office
- \$5,000 cash rating
- Low weight barrier material that optimise cost, transport and installation
- Body and door are made from 12mm solid steel
- Digital electronic lock
- Backup battery pack provided and over-ride key
- Fixed shelf included providing organised storage

PRODUCT SPECIFICATIONS

| Model | EXTERNAL (mm) | | | INTERNAL (mm) | | | Volume (litres) | Weight (kg) | Standard internal fittings |
|-------|---------------|-------|-------|---------------|-------|-------|-----------------|-------------|----------------------------|
| | Height | Width | Depth | Height | Width | Depth | | | |
| SC 1 | 355 | 355 | 355 | 330 | 330 | 290 | 32 | 75 | 1 shelf |

Dimensions exclude handle and hinge projections.



E-SLOT SAFE

BURGLARY-RESISTANT SAFE



KEY FEATURES

- Burglary resistant protection small deposit safe designed to provide safe secure storage for cash
- Up to \$5000 cash rating
- Body and door are made from 12mm solid steel
- Allows anyone to drop items into the slot
- Access only by digital electronic lock
- Backup battery pack provided
- Fixed shelf included

PRODUCT SPECIFICATIONS

| Model | EXTERNAL (mm) | | | INTERNAL (mm) | | | Volume (litres) | Weight (kg) | Standard internal fittings |
|-------|---------------|-------|-------|---------------|-------|-------|-----------------|-------------|----------------------------|
| | Height | Width | Depth | Height | Width | Depth | | | |
| SES | 355 | 355 | 355 | 330 | 330 | 290 | 32 | 75 | 1 shelf |

Dimensions exclude handle and hinge projections.

* We recommend that these safes are delivered and installed by a professional safe installer. Please refer to our Preferred Chubb safes Installer list on page 33.



PRODUCT SHOWN: OMNI SIZE 4

OMNI

BURGLARY- & FIRE-RESISTANT SAFE



KEY FEATURES

- Combined fire and burglary protection in office environments
- \$25,000 cash rating
- Certified to JIS S 1037:1989 offers up to 45 minutes paper fire protection
- Tested to the highest quality in its class against attack. Approved by Sold Secure to Gold Standard for burglary protection. Sold Secure is an independent testing authority approved by the British Home Office
- Secured by an electronic lock as standard
- 10mm solid steel door
- Supplied with glass relocker
- Available in seven sizes
- Complete with a standard internal steel shelf adjustable in intervals
- Solid bolt on hinged side of the door

PRODUCT SPECIFICATIONS

| Model | EXTERNAL (mm) | | | INTERNAL (mm) | | | Volume (litres) | Weight (kg) | Standard internal fittings |
|-------|---------------|-------|--------|---------------|-------|-------|-----------------|-------------|----------------------------|
| | Height | Width | Depth* | Height | Width | Depth | | | |
| Sz 1 | 410 | 360 | 360 | 278 | 230 | 230 | 15 | 120 | 1 drawer |
| Sz 2 | 488 | 435 | 435 | 356 | 280 | 240 | 33 | 180 | 1 shelf, 1 drawer |
| Sz 3 | 590 | 435 | 445 | 458 | 305 | 305 | 43 | 210 | 1 shelf, 1 drawer |
| Sz 4 | 590 | 550 | 550 | 458 | 420 | 420 | 81 | 300 | 1 shelf, 1 drawer |
| Sz 5 | 717 | 550 | 550 | 585 | 420 | 420 | 103 | 340 | 1 shelf, 1 drawer |
| Sz 6 | 894 | 550 | 550 | 762 | 420 | 420 | 134 | 400 | 1 shelf, 1 drawer |
| Sz 7 | 1047 | 640 | 640 | 915 | 510 | 510 | 236 | 540 | 1 shelf, 1 drawer |

* Handle projection is 56mm.

* We recommend that these safes are delivered and installed by a professional safe installer. Please refer to our Preferred Chubb Safes Installer list on page 33.



MODEL SHOWN: OMNI DRAWER TRAP SIZE 2

OMNI DRAWER TRAP



BURGLARY-RESISTANT SAFE

KEY FEATURES

- Combined fire and burglary protection for home, office and retail environments where access to the safe is required for deposit without the need to open the safe
- \$25,000 Cash Rating
- Tested to the highest quality in its class against attack. Approved by Sold Secure to Gold Standard for burglary protection. Sold Secure is an independent testing authority approved by the British Home Office
- Providing a Drawer Trap adds an additional layer of security as only one person is required to have full access to the safe
- Secured with key lock as standard
- 10mm solid steel door
- Safe is fitted with a drawer trap deposit
- Supplied with glass relocker
- A second lock can be fitted (sizes 5 and 7)
- Available in 3 sizes
- Deposit draw fitted with Mauer key lock

PRODUCT SPECIFICATIONS

| Model | EXTERNAL (mm) | | | INTERNAL (mm) | | | Volume (litres) | Weight (kg) | Standard internal fittings |
|-------|---------------|-------|--------|---------------|-------|-------|-----------------|-------------|----------------------------|
| | Height | Width | Depth* | Height | Width | Depth | | | |
| Sz 2 | 742 | 435 | 435 | 356 | 305 | 305 | 33 | 270 | 1 anti-spill plate |
| Sz 5 | 917 | 550 | 550 | 585 | 420 | 420 | 103 | 515 | 1 anti-spill plate |
| Sz 7 | 1301 | 640 | 640 | 915 | 510 | 510 | 236 | 866 | 1 anti-spill plate |

* Handle projection is 56mm.

* We recommend that these safes are delivered and installed by a professional safe installer. Please refer to our Preferred Chubb safes Installer list on page 33.



MODEL SHOWN: DUOGUARD 450

DUOGUARD

BURGLARY- & FIRE-RESISTANT SAFE

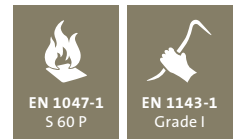

KEY FEATURES

- Combined resistance against burglary and fire, ideal for office and retail environments
- Certified by ECB•S according to EN 1143-1, Grade I for burglary protection
- Certified by ECB•S according to EN 1147-1 for fire protection of paper documents for up to 60 minutes
- Dualite new composite barrier-material to ensure dual protection while reducing total weight to minimise transport and installation cost
- Three-way solid steel boltwork, active relocker and anti-drilling plates for enhanced security
- Ergonomic soft-touch handle for comfort in use
- Maximised storage capacity with customisable capabilities
- Lock alternatives: EN 1300-certified Class A key lock and/or EN 1300-certified Class B electronic lock
- Choice of 5 sizes ranging from 62 to 443 litres
- Optional internal fittings: removable shelf, extendable shelf, lockable drawer, lockable compartment, extensible tray, file frame. Data media insert certified 60 Diskette by NT Fire 017 for up to 60 minutes fire protection. Read more on page 34

PRODUCT SPECIFICATIONS

| Model | EXTERNAL (mm) | | | INTERNAL (mm) | | | Volume (litres) | Weight (kg) | Standard internal fittings |
|-------|---------------|-------|-------|---------------|-------|-------|-----------------|-------------|----------------------------|
| | Height | Width | Depth | Height | Width | Depth | | | |
| 60 | 530 | 500 | 521 | 430 | 400 | 360 | 62 | 115 | 1 shelf |
| 110 | 690 | 600 | 561 | 590 | 500 | 386 | 114 | 161 | 2 shelves |
| 150 | 875 | 600 | 561 | 775 | 500 | 386 | 150 | 196 | 2 shelves |
| 350 | 1600 | 675 | 585 | 1500 | 575 | 410 | 354 | 352 | 3 shelves |
| 450 | 1850 | 675 | 615 | 1750 | 575 | 440 | 443 | 415 | 4 shelves |

SPECIFICATIONS FOR **OPTIONAL FITTINGS** ARE AVAILABLE ON PAGE 34

Dimensions exclude handle and hinge projections.

* We recommend that these safes are delivered and installed by a professional safe installer. Please refer to our Preferred Chubb Safes Installer list on page 33.



OXLEY MK III

BURGLARY- & FIRE-RESISTANT SAFE



KEY FEATURES

- Combined fire and burglary protection for business and retailers
- \$60,000 Cash Rating
- Certified by ECB+S according to EN 1047-1 for up to 60 minutes
- Tested to the highest quality in its class against attack. Approved by Sold Secure to Gold Standard for burglary protection. Sold Secure is an independent testing authority approved by the British Home Office
- All Chubb safes' locks are tested to conform with the requirements of EN 1143-1
- 6 Sided Tool and Torch Resistant Barrier (TDR)
- Base fixing is standard on all models
- Lock alternatives:
 - Combination lock and key lock or
 - Electronic lock and key lock
- Stocked in 3 sizes. Additional sizes available on special request
- The Oxley Mark III can be customised with a choice of locking options, deposits, shelves and lockable drawer deposits in order to meet customer requirements. Read more on page 34

PRODUCT SPECIFICATIONS

| Model | EXTERNAL (mm) | | | INTERNAL (mm) | | | Volume (litres) | Weight (kg) | Standard internal fittings |
|-------|---------------|-------|-------|---------------|-------|-------|-----------------|-------------|----------------------------|
| | Height | Width | Depth | Height | Width | Depth | | | |
| Sz 0 | 568 | 508 | 450 | 400 | 340 | 209 | 28 | 274 | 1 shelf |
| Sz 1 | 628 | 528 | 603 | 460 | 360 | 360 | 60 | 330 | 1 shelf, 2 drawers |
| Sz 3 | 1018 | 668 | 663 | 850 | 500 | 420 | 179 | 663 | 2 shelves, 2 drawers |
| Sz 5 | 1468 | 668 | 773 | 1300 | 500 | 530 | 345 | 1054 | 2 shelves, 2 drawers |

SPECIFICATIONS FOR **OPTIONAL FITTINGS** ARE AVAILABLE ON PAGE 34

Dimensions exclude handle and hinge projections.

* We recommend that these safes are delivered and installed by a professional safe installer. Please refer to our Preferred Chubb safes Installer list on page 33.



EUROPA G III

BURGLARY-RESISTANT SAFE

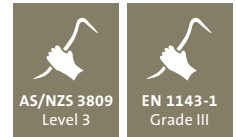

KEY FEATURES

- Burglary protection for high level business and financial institutions
- \$100,000 Cash Rating
- Certified by ECB•S according to EN 1143-1
- Certified to Level 3 according to AS/NZS 3809 (Safes and Strongrooms)
- Chubbsafes special barrier material is applied in the construction of the safe to protect against varying kinds of burglary attack
- Active and passive relocking system
- Torch and Drill Resistant (TDR)
- Lock alternatives:
 - Combination lock and key lock or
 - Electronic lock and key lock
 - Optional time delay locks available
- Choice of 4 sizes ranging from 179 to 503 litres
- Optional internal fittings: deposits, shelves and lockable drawer deposits in order to meet customer requirements. Read more on page 34

PRODUCT SPECIFICATIONS

| Model | EXTERNAL (mm) | | | INTERNAL (mm) | | | Volume (litres) | Weight (kg) | Standard internal fittings |
|-------|---------------|-------|-------|---------------|-------|-------|-----------------|-------------|----------------------------|
| | Height | Width | Depth | Height | Width | Depth | | | |
| Sz 3 | 1018 | 668 | 663 | 850 | 500 | 420 | 179 | 715 | 2 shelves, 2 drawers |
| Sz 4 | 1208 | 668 | 773 | 1040 | 500 | 530 | 276 | 920 | 2 shelves, 2 drawers |
| Sz 5 | 1468 | 668 | 773 | 1300 | 500 | 530 | 345 | 1084 | 2 shelves, 2 drawers |
| Sz 6 | 1796 | 903 | 663 | 1628 | 735 | 420 | 503 | 1400 | 2 shelves, 2 drawers |

SPECIFICATIONS FOR **OPTIONAL FITTINGS** ARE AVAILABLE ON PAGE 34

Dimensions exclude handle and hinge projections.

* We recommend that these safes are delivered and installed by a professional safe installer. Please refer to our Preferred Chubbsafes Installer list on page 33.



MODEL SHOWN: EUROPA SIZE 6

EUROPA GV

BURGLARY-RESISTANT SAFE

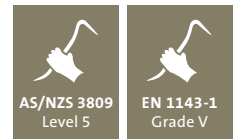

KEY FEATURES

- Burglary protection for high level business and financial institutions
- \$300,000 Cash Rating
- Certified by ECB•S according to EN 1143-1
- Certified to Level 5 according to AS/NZS 3809 (Safes and Strongrooms)
- Chubb safes special barrier material is applied in the construction of the safe to protect against varying kinds of burglary attack
- Active and passive relocking system
- Torch and Drill Resistant (TDR)
- Lock alternatives:
 - Combination lock and key lock or
 - Electronic lock and key lock
 - Optional time delay locks available
- Choice of 2 sizes ranging from 400 to 503 litres
- Optional internal fittings: deposits, shelves and lockable drawer deposits in order to meet customer requirements. Read more on page 34

PRODUCT SPECIFICATIONS

| Model | EXTERNAL (mm) | | | INTERNAL (mm) | | | Volume (litres) | Weight (kg) | Standard internal fittings |
|-------|---------------|-------|-------|---------------|-------|-------|-----------------|-------------|----------------------------|
| | Height | Width | Depth | Height | Width | Depth | | | |
| Sz 5* | 1468 | 668 | 773 | 1338 | 538 | 554 | 400 | 1150 | 2 shelves, 2 drawers |
| Sz 6 | 1796 | 903 | 663 | 1666 | 773 | 444 | 572 | 1520 | 2 shelves, 2 drawers |

SPECIFICATIONS FOR **OPTIONAL FITTINGS** ARE AVAILABLE ON PAGE 34

Dimensions exclude handle and hinge projections. *Denotes that items not stocked – order as required.

*We recommend that these safes are delivered and installed by a professional safe installer. Please refer to our Preferred Chubb safes Installer list on page 33.



MODEL SHOWN: ARCHIVE CABINET 450 KL



ARCHIVE CABINET

FIRE-RESISTANT DOCUMENT CABINET

KEY FEATURES

- Storage cabinets with fire protection in your office
- Double-wall construction with special fire-resistant barrier material
- Three-way solid steel boltwork for enhanced security
- Anchor points in base to fix the cabinet to the floor
- Wide fitting capabilities to suit a variety of storage requirements
- Supplied with an EN 1300-certified Class A key lock
- Choice of 4 sizes ranging from 325 to 880 litres
- Optional internal fittings: removable shelf, suspension file frame, lockable compartment. Read more on page 34

PRODUCT SPECIFICATIONS

| Model | EXTERNAL (mm) | | | INTERNAL (mm) | | | Volume (litres) | Weight (kg) | Standard internal fittings |
|-------|---------------|-------|-------|---------------|-------|-------|-----------------|-------------|----------------------------|
| | Height | Width | Depth | Height | Width | Depth | | | |
| 325 | 1500 | 700 | 550 | 1290 | 594 | 430 | 325 | 95 | 3 shelves |
| 450 | 1950 | 700 | 550 | 1780 | 594 | 430 | 450 | 120 | 4 shelves |
| 640 | 1950 | 950 | 550 | 1780 | 844 | 430 | 640 | 150 | 4 shelves |
| 880 | 1950 | 1260 | 550 | 1780 | 1154 | 430 | 880 | 200 | 4 shelves |

SPECIFICATIONS FOR **OPTIONAL FITTINGS** ARE AVAILABLE ON PAGE 34

Dimensions exclude handle and hinge projections.

* We recommend that these safes are delivered and installed by a professional safe installer. Please refer to our Preferred Chubb Safes Installer list on page 33.



MODEL SHOWN: DOCUMENT PROTECTION CABINETS 400W

DPC

FIRE-RESISTANT DOCUMENT CABINET



KEY FEATURES

- High-capacity storage solution with fire protection, ideal for office environments such as banks, financial institutions...
- Certified by Underwriter's Laboratories according to UL 72 Class 350 for up to 120 minutes fire protection
- Automated mechanism to ensure bolts throw whenever the door is closed
- Interlocking systems for double doors models to prevent the safe from being left open
- Anchoring kit to fix the safe on the floor and prevent unauthorised removal
- Lock alternatives:
 - Series of key locks
 - Combination lock
 - Series of electronic locks
- Choice of high-capacity sizes from 240 to 670 litres
- Optional internal fittings: removable shelf, pull-out file frame, pull-out shelf, lockable drawer, lockable cupboard. Read more on page 34

PRODUCT SPECIFICATIONS

| Model | EXTERNAL (mm) | | | INTERNAL (mm) | | | Volume (litres) | Weight (kg) | Standard internal fittings |
|-------|---------------|-------|-------|---------------|-------|-------|-----------------|-------------|----------------------------|
| | Height | Width | Depth | Height | Width | Depth | | | |
| 240 | 1209 | 759 | 605 | 1050 | 600 | 382 | 240 | 315 | 2 shelves |
| 400W | 1209 | 1160 | 605 | 1050 | 1000 | 382 | 401 | 500 | 2 shelves |
| 320 | 1559 | 759 | 605 | 1400 | 600 | 382 | 321 | 395 | 3 shelves |
| 670 | 1909 | 1160 | 605 | 1750 | 1000 | 382 | 670 | 650 | 4 shelves |

SPECIFICATIONS FOR **OPTIONAL FITTINGS** ARE AVAILABLE ON PAGE 34

Dimensions exclude handle and hinge projections.

* We recommend that these safes are delivered and installed by a professional safe installer. Please refer to our Preferred Chubb safes Installer list on page 33.



MODEL SHOWN: FIRE FILE 25" 4 DRAWERS

FIRE FILE 25"

FIRE-RESISTANT DOCUMENT FILE



KEY FEATURES

- Fire resistant filing cabinet for document storage in office environments
- Certified by Underwriter's Laboratories according to Standard 72, Class 350 Endurance for up to 60 minutes fire protection
- Interlocking system preventing more than one drawer from opening at once and eliminating risk of tipping
- Day-catch fitted to each drawer to ensure that the contents are protected from fire as long as a drawer has been pushed closed, even if the cabinet is unlocked
- The contents of the closed drawers are completely protected from fire even if one of the drawers has left open.
- High-quality steel sliders for easy access and use.
- Efficient design for high-capacity storage: available in 2 or 4 drawers
- Supplied with key lock

PRODUCT SPECIFICATIONS

| Model | EXTERNAL (mm) | | | DRAWER (mm) | | | Volume (litres) | Weight (kg) | Fittings |
|---------------------------------------|---------------|-------|-------|-------------|-------|-------|-----------------|-------------|----------|
| | Height | Width | Depth | Height | Width | Depth | | | |
| 25" Fire Protection 60 minutes | | | | | | | | | |
| 2 drawers | 784 | 551 | 635 | 290 | 387 | 460 | 104 | 164 | Keylock |
| 4 drawers | 1510 | 551 | 635 | 290 | 387 | 460 | 208 | 291 | Keylock |

Dimensions exclude handle and hinge projections.

* We recommend that these safes are delivered and installed by a professional safe installer. Please refer to our Preferred Chubb Safes Installer list on page 33.



MODEL SHOWN: FIRE FILE 31" 4 DRAWERS

FIRE FILE 31"

FIRE-RESISTANT DOCUMENT FILE



KEY FEATURES

- Fire resistant filing cabinet for document storage in office environments
- Certified by Underwriter's Laboratories according to Standard 72, Class 350 Endurance for up to 120 minutes fire protection
- Interlocking system preventing more than one drawer from opening at once and eliminating risk of tipping
- Day-catch fitted to each drawer to ensure that the contents are protected from fire as long as a drawer has been pushed closed, even if the cabinet is unlocked
- The contents of the closed drawers are completely protected from fire even if one of the drawers has left open.
- High-quality steel sliders for easy access and use.
- Efficient design for high-capacity storage: available in 2 and 4 drawers
- Lock alternatives:
 - Key lock
 - Programmable electronic lock

PRODUCT SPECIFICATIONS

| Model | EXTERNAL (mm) | | | DRAWER (mm) | | | Volume (litres) | Weight (kg) | Fittings |
|--|---------------|-------|-------|-------------|-------|-------|-----------------|-------------|----------------|
| | Height | Width | Depth | Height | Width | Depth | | | |
| 2 hours Fire Protection for 120 minutes | | | | | | | | | |
| 2 drawers | 784 | 551 | 779 | 290 | 387 | 604 | 136 | 197 | S&G Titan & KL |
| 4 drawers | 1510 | 551 | 779 | 290 | 387 | 604 | 272 | 328 | S&G Titan & KL |

Dimensions exclude handle and hinge projections.

* We recommend that these safes are delivered and installed by a professional safe installer. Please refer to our Preferred Chubb safes Installer list on page 33.



MODEL SHOWN: DATAGUARD NT 80 EL

DATAGUARD NT

FIRE-RESISTANT DATA MEDIA SAFE



KEY FEATURES

- Fire-resistant safe for data media protection
- Certified by SP Technical Research Institute of Sweden according to NT Fire 017 – 120 Diskette for up to 120 minutes data media fire protection
- Easy slam action closing for full fire protection without the door being locked
- Effective design with single door safe for maximised storage
- Lock alternatives:
 - Key lock
 - Programmable electronic lock
- Choice of 3 sizes ranging from 48 to 128 litres
- Optional internal fittings: adjustable shelf, extendable drawer. Read more on page 34

PRODUCT SPECIFICATIONS

| Model | EXTERNAL (mm) | | | INTERNAL (mm) | | | Volume (litres) | Weight (kg) | Standard internal fittings |
|-------|---------------|-------|-------|---------------|-------|-------|-----------------|-------------|----------------------------|
| | Height | Width | Depth | Height | Width | Depth | | | |
| 40 | 700 | 546 | 566 | 450 | 346 | 306 | 48 | 190 | 1 shelf, 1 drawer |
| 80 | 1025 | 546 | 590 | 775 | 346 | 330 | 89 | 263 | 1 shelf, 2 drawers |
| 120 | 1025 | 702 | 590 | 775 | 502 | 330 | 128 | 330 | 1 shelf, 2 drawers |

SPECIFICATIONS FOR **OPTIONAL FITTINGS** ARE AVAILABLE ON PAGE 34

*External heights and depths include plinth and handle projection. **Internal heights and widths are also equal to the clear opening measurements.

* We recommend that these safes are delivered and installed by a professional safe installer. Please refer to our Preferred Chubb Safes Installer list on page 33.



MODEL SHOWN: DATAPLUS+ 1 KL

DATAPLUS+

FIRE-RESISTANT DATA MEDIA SAFE



KEY FEATURES

- Combined fire and burglary protection for data media in office environments
- Certified by ECB•S according to EN 14450, Level S2 for burglary protection
- Certified by ECB•S according to EN 1047-1 for up to 120 minutes data media fire protection
- Tested by Underwriter's Laboratories according to UL 72
- Low weight barrier material that optimise cost, transport and installation
- Easy slam-action emergency closing
- Anchor point to prevent unauthorised removal
- Lock alternatives:
 - Key lock
 - Series of electronic locks with audit trail
- Choice of 5 sizes ranging from 111 to 556 litres
- Optional internal fittings: adjustable shelf, pull-out platform, lockable cupboard (size 5), suspended pocket shelf. Read more on page 34

PRODUCT SPECIFICATIONS

| Model | EXTERNAL (mm) | | | INTERNAL (mm) | | | Volume (litres) | Weight* (kg) |
|--------|---------------|-------|---------|---------------|-------|-------|-----------------|--------------|
| | Height | Width | Depth** | Height | Width | Depth | | |
| Size 1 | 911 | 746 | 780 | 565 | 490 | 400 | 111 | 315 |
| Size 2 | 1191 | 746 | 780 | 845 | 490 | 400 | 167 | 390 |
| Size 3 | 1471 | 746 | 780 | 1125 | 490 | 400 | 221 | 490 |
| Size 4 | 1941 | 746 | 780 | 1595 | 490 | 400 | 313 | 640 |
| Size 5 | 1941 | 1036 | 830 | 1570 | 780 | 450 | 556 | 860 |

SPECIFICATIONS FOR **OPTIONAL FITTINGS** ARE AVAILABLE ON PAGE 34

*Weight refers to an empty cabinet. **Gross measurement inc. 60mm for handle which can be removed for installation.

* We recommend that these safes are delivered and installed by a professional safe installer. Please refer to our Preferred ChubbSafes Installer list on page 33.



PRODUCT SHOWN: COUNTER UNIT

COUNTER UNIT

BURGLARY-RESISTANT SAFE



KEY FEATURES

- Ready-to-use deposit solution at cash tills
- Under the counter installation for discreet use
- Solid sheet steel construction
- Easy-to-reach deposit slot
- Alternative locks: 2 key locks, one to open the storage unit and 1 to release it from the counter

PRODUCT SPECIFICATIONS

| Model | EXTERNAL (mm) | | | Weight (kg) | Deposit capacity |
|---------|---------------|-------|-------|-------------|---------------------|
| | Height | Width | Depth | | |
| ACU 350 | 235 | 105 | 190 | 2.4 | up to 350 banknotes |

Dimensions exclude handle and hinge projections.



PISTOL SAFE

BURGLARY-RESISTANT SAFE



KEY FEATURES

- Designed to protect pistols from theft
- Supplied with a key lock
- Incorporates anti-drill protection
- Welded lock strap behind lock

PRODUCT SPECIFICATIONS

| Model | EXTERNAL (mm) | | | INTERNAL (mm) | | | Weight (kg) | Standard internal fittings |
|-------------|---------------|-------|-------|---------------|-------|-------|-------------|----------------------------|
| | Height | Width | Depth | Height | Width | Depth | | |
| Pistol Safe | 140 | 320 | 250 | 128 | 308 | 218 | 16 | – |

Dimensions exclude handle and hinge projections.



DEPOSIT CONTAINER



BURGLARY-RESISTANT SAFE

KEY FEATURES

- Ideal for a small retailer to secure documents or cash
- Provides access to multiple people without reducing security
- Convenient deposit of cash
- 8mm solid steel construction
- Electronic or key lock

PRODUCT SPECIFICATIONS

| Model | EXTERNAL (mm) | | | INTERNAL (mm) | | | Weight (kg) | Standard internal fittings |
|---------|---------------|-------|-------|---------------|-------|-------|-------------|----------------------------|
| | Height | Width | Depth | Height | Width | Depth | | |
| T1-27KD | 270 | 350 | 345 | 260 | 340 | 290 | 20 | – |

Dimensions exclude handle and hinge projections.



DRUG CABINET

BURGLARY-RESISTANT SAFE



KEY FEATURES

- Suitable for storage of prescription drugs
- Ideal for hospitals, doctor's surgeries, pharmacies or any other situation where securing stock is required
- Supplied with key lock
- Constructed from 10mm solid steel
- Each model is supplied with shelves
- Available in 3 sizes
- Welded strap on lock body
- Boltwork encased when retracted
- Complies with all state codes

PRODUCT SPECIFICATIONS

| Model | EXTERNAL (mm) | | | INTERNAL (mm) | | | Volume (litres) | Weight (kg) | Standard internal fittings |
|-------|---------------|-------|-------|---------------|-------|-------|-----------------|-------------|----------------------------|
| | Height | Width | Depth | Height | Width | Depth | | | |
| DC1 | 350 | 240 | 150 | 330 | 220 | 130 | 10 | 27 | 3 shelves |
| DC2 | 600 | 450 | 150 | 580 | 430 | 130 | 32 | 66 | 4 shelves |
| DC3 | 900 | 600 | 300 | 880 | 580 | 260 | 132 | 160 | 5 shelves |

Dimensions exclude handle and hinge projections.

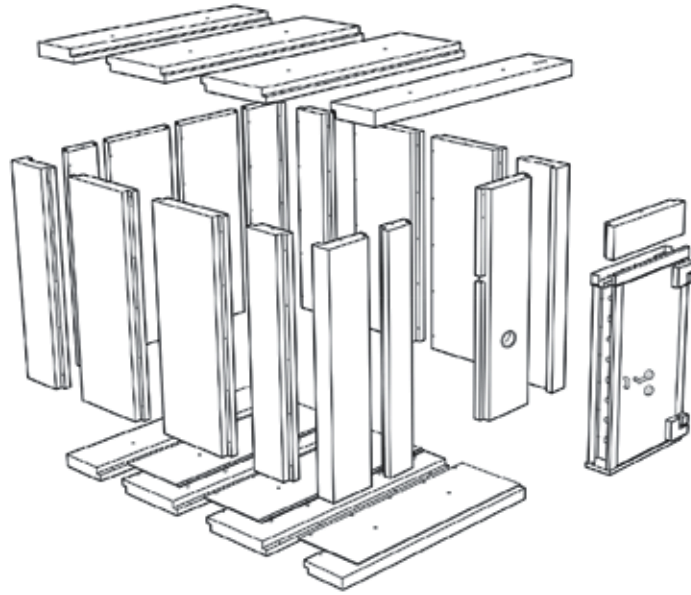

INSTAVault

BURGLARY-RESISTANT VAULT

KEY FEATURES

- Patented Chubb safes barrier materials
- 3 levels of security with panel thickness of 75mm, 110mm and 150mm
- Standard, extended and multi-bay sizes can accommodate almost any space requirement
- Full engineering and install support services provided
- Customised internal and external fit-outs available
- Install on a prepared concrete surface or for added security add an InstaVault™ floor system
- Fitted with an emergency breather tube. Emergency powered ventilators can be provided as an optional extra
- Extend, reduce and relocate your vault as your needs change

PRODUCT SPECIFICATIONS

| Model | Barrier (mm) | EXTERNAL (mm) | | | INTERNAL (mm) | | | Match with Chubb safes Vault Door |
|-------|--------------|---------------|-------|-------|---------------|-------|-------|-----------------------------------|
| | | Height* | Width | Depth | Height | Width | Depth | |
| LS75 | 75 | 2475 | 2650 | 2650 | 2400 | 2500 | 2500 | Holsworthy 70mm |
| MS110 | 110 | 2510 | 2720 | 2720 | 2400 | 2500 | 2500 | Pacific 100mm |
| HS150 | 150 | 2550 | 2800 | 2800 | 2400 | 2500 | 2500 | Bankers 130mm |

* External height dimensions without an optional Chubb safes InstaVault™ floor.

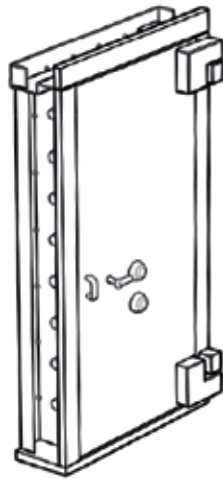

VAULT DOORS

BURGLARY-RESISTANT VAULT DOORS

KEY FEATURES

- Patented Chubb safes barrier materials
- Standard locking configurations can be complimented by alternative digital, key and KCL locks
- TOR barriers from 70mm to 130mm
- Custom and oversized versions available
- Relocking devices provided for enhanced attack protection
- Standard internal emergency release mechanism

PRODUCT SPECIFICATIONS

| Model | Barrier (mm) | CLEAR OPENING | | | Locking | Weight (kg) | MASONRY OPENING | |
|------------|--------------|---------------|------------|-----------------------|--------------------|-------------|-----------------|------------|
| | | Height (mm) | Width (mm) | InstaVault Wall (mm)* | | | Height (mm) | Width (mm) |
| Holsworthy | 70 | 1917 | 920 | 75 | 1 x 3 KCL + 1 x KL | 820 | 2050 | 1080 |
| Pacific | 100 | 1917 | 920 | 110 | 2 x 4 WKCL | 1020 | 2050 | 1080 |
| Bankers | 130 | 1917 | 920 | 150 | 2 x 4 WKCL | 1280 | 2050 | 1080 |

* Chubb safes Vault Doors are matched to Chubb safes InstaVault™ solutions, but are also used for poured vault installations.



Chubbsafes Preferred Installers

NSW - METRO SAFES

Dean Gadd – 1800 103 311 or 0418 300 321
5/28 Oramzi Rd, Girraween NSW 2145
admin@metrosafes.com.au

ACT - ASI LOCKSMITHS

02 6251 1233
admin@asilocksmiths.com.au
61/63 Oatley Ct, Belconnen ACT 2617

VIC - ENDORSED CARRIERS & STORERS

Narelle Walkerden – 03 9328 3050 or 0412 519 273
narelle@endorsed.com.au
241 Roden St, West Melbourne VIC 3003

QLD - ACTIVE SAFES

Brendan or Amanda – 07 3800 7444
brendan@activesafes.com.au
amanda@activesafes.com.au
2/56-62 Johnson Rd, Hillcrest QLD 4118

SA - ASKWITH COMPANY

Paul Stokes – 0419 750 133
paul.s@askwithcompany.com.au
76 Unley Road, Unley SA 5061

WA - ASKWITH COMPANY

Randy Witt – 08 9451 5029
randy.w@askwithcompany.com.au
133 Welshpool Rd, Welshpool WA 6106

Disclaimer: Gunnebo or Chubbsafes are in no way affiliated with these companies and we are not responsible for any service or goods provided by these companies.

SPECIAL FITTINGS

ARCHIVE CABINET

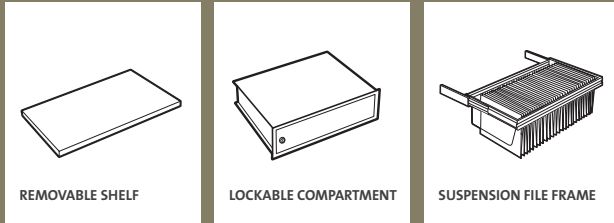

REMOVABLE SHELF

LOCKABLE COMPARTMENT

SUSPENSION FILE FRAME

DATAGUARD NT

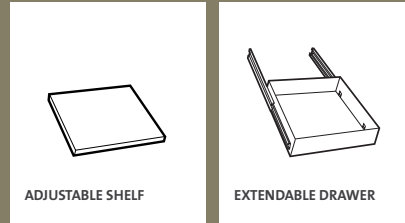

ADJUSTABLE SHELF

EXTENDABLE DRAWER

DATAPLUS+

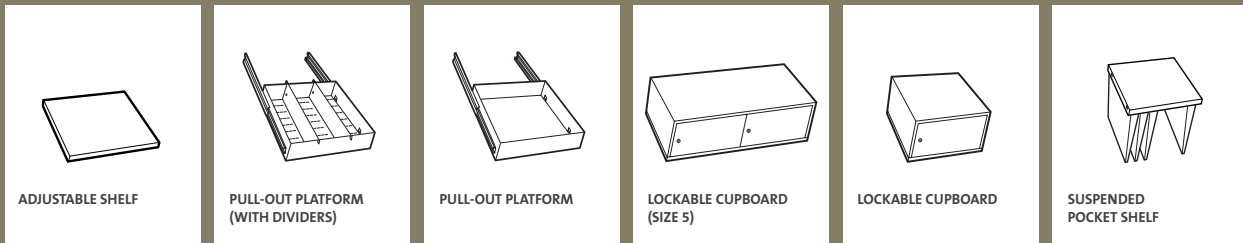

ADJUSTABLE SHELF

PULL-OUT PLATFORM
(WITH DIVIDERS)

PULL-OUT PLATFORM

LOCKABLE CUPBOARD
(SIZE 5)

LOCKABLE CUPBOARD

SUSPENDED
POCKET SHELF

DPC

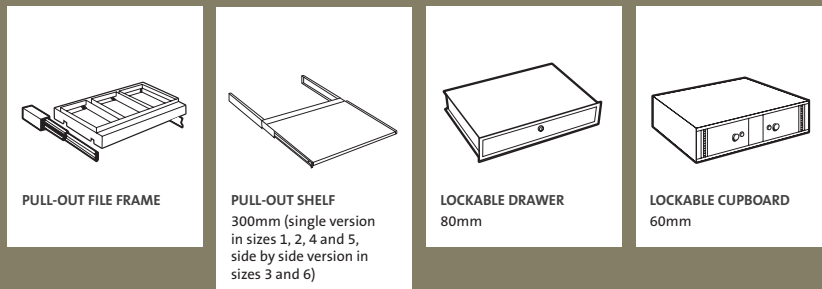

PULL-OUT FILE FRAME

PULL-OUT SHELF
300mm (single version
in sizes 1, 2, 4 and 5,
side by side version in
sizes 3 and 6)

LOCKABLE DRAWER
80mm

LOCKABLE CUPBOARD
60mm

* Please note: any special fittings required will incur additional costs. In addition, please allow 12-14 weeks lead time.

DUOGUARD

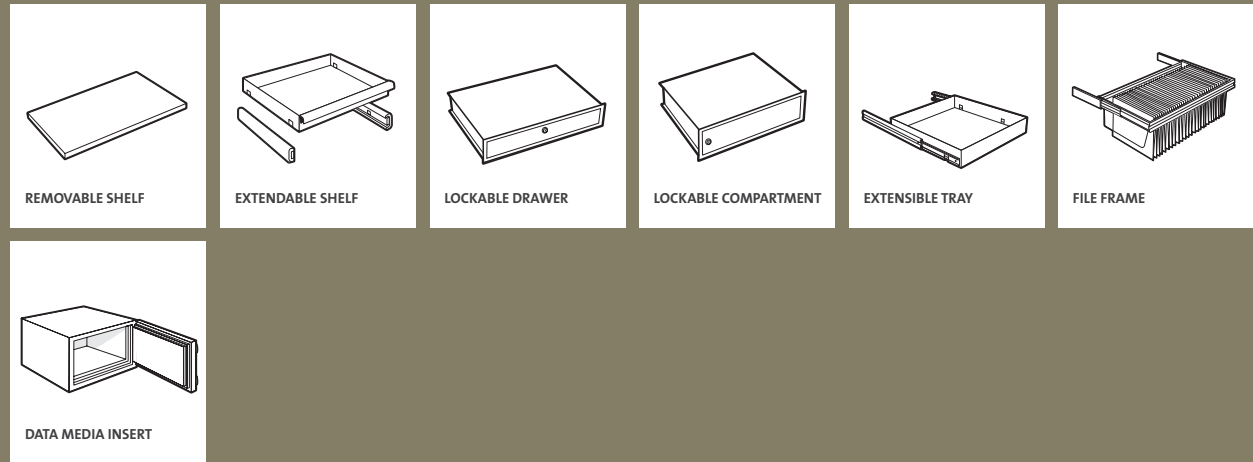

EUROPA

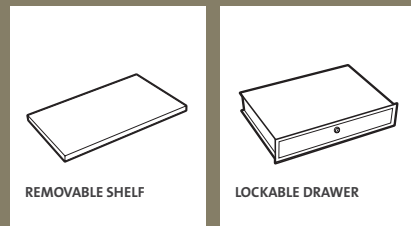

OXLEY MK III

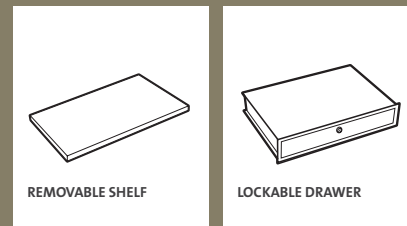

www.chubbsafes.com.au

Authorised dealer

Authorised Dealer



T: 1300 764 971
E: sales@safeguardsafes.com.au
W: www.safeguardsafes.com.au